

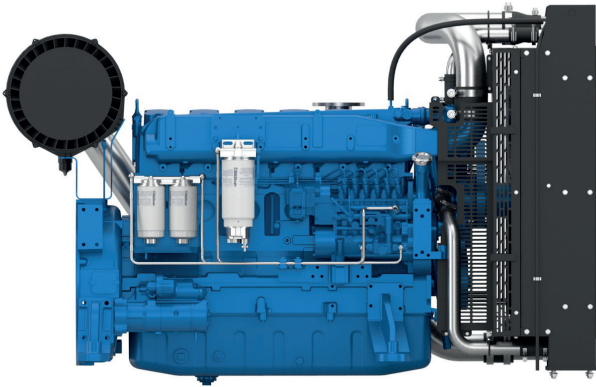

6M16

PowerKit ESP/PRP/COP Diesel Engine



Bore & Stroke (mm)	126 x 130
Displacement (L)	9.7
N° of Cylinders	6
Cylinders Arrangement	In line
Fuel System	Mechanical
Governor (Gov.)	Electronic
Aspiration (Asp.)	Turbocharged & air-to-air cooled

Customer benefits

Warranty terms – 2 yrs unlimited PRP, 4 yrs/800h ESP
 50°C Cooling package standard with low derating
 Low fuel consumption across the range
 Extended mean time between overhauls (MTBO)

ESP/ PRP									
Diesel Engine Models	Gross Engine Output		Typical Generator Output				RPM	Asp.	Gov.
	ESP	PRP	ESP		PRP				
	kWm		kWe	kVA	kWe	kVA			
6M16G2D0/S	204	187	176	220	160	200	1500	T/A-A	ELEC
6M16G4D0/S	238	216	200	250	184	230	1500	T/A-A	ELEC
6M16G6D0/S	264	240	220	275	200	250	1500	T/A-A	ELEC
6M16G300/5	280	255	240	300	220	275	1500	T/A-A	ELEC
6M16G350/5	320	291	280	350	256	320	1500	T/A-A	ELEC
6M16G2D0/S	238	216	200	250	180	225	1800	T/A-A	ELEC
6M16G4D0/S	264	240	224	280	200	250	1800	T/A-A	ELEC
6M16G6D0/S	288	262	250	313	227	284	1800	T/A-A	ELEC
6M16G308/6	360	327	308	385	280	350	1800	T/A-A	ELEC

*Please note that models ending with S are switchable 50/60 Hz engines.

COP									
COP Diesel Engine Models	Gross Engine Output		Typical Generator Output				RPM	Asp.	Gov.
	COP	PRP	COP		PRP				
	kWm		kWe	kVA	kWe	kVA			
6M16G2D0/5	204	240	160	200	200	250	1500	T/A-A	ELEC
6M16G4D0/5	238	275	200	250	240	300	1500	T/A-A	ECU
6M16G2D0/6	204	262	169.6	212	224.8	281	1800	T/A-A	ELEC
6M16G4D0/6	276	314	240	300	272	340	1800	T/A-A	ECU

Dimensions and dry weight (mm/kg)

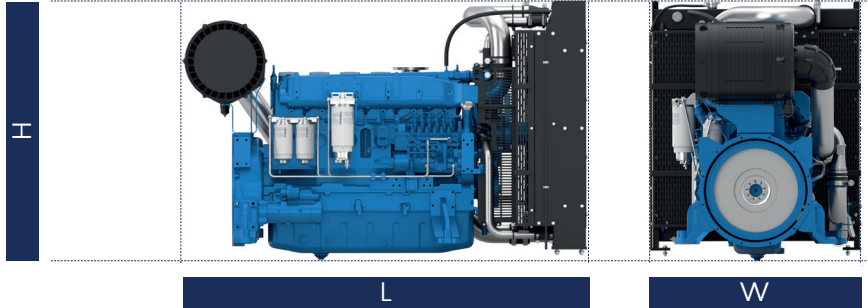

Diesel Engine	Speed RPM	Dimensions and dry weights including radiator			
		L mm	W mm	H mm	WEIGHT kg
6M16G2D0/S	1500/1800	1983	1033	1264	1020
6M16G4D0/S	1500/1800	1983	1033	1264	1020
6M16G6D0/S	1500/1800	1983	1033	1264	1020
6M16G300/5	1500	1983	1033	1264	972
6M16G350/5	1500	1982	1082	1310	1021
6M16G308/6	1800	1982	1082	1310	1021

Standard Equipment

Engine and block	Cast iron frame style body structure One-piece forged crankshaft Separate cast iron cylinder heads and replaceable dry cylinder liners Aluminum alloy pistons with oil cooling gallery
Cooling System	Radiator and hoses supplied separately Thermostatically-controlled system with belt driven coolant pump and pusher fan
Lubrication system	Flat bottom large capacity oil pan Spin-on full-flow lube oil filter High capacity gear driven lube oil pump
Fuel system	P type fuel injection pump and injector for higher inject pressure Duplex fine filter and water separation filter assembly with transparent cup for better efficiency
Air intake and exhaust system	Mid-position and below inlet turbocharger optimized for genset application Special rear mounted air filter with restriction indicator Exhaust manifold shield for heat isolating
Electrical System	24 Vdc electric starter motor and battery charging alternator LOP + HWT sensors
Flywheel and housing	SAE 1 flywheel housing and 14" flywheel

Ratings definitions

Emergency Standby Power (ESP)

Emergency Standby Power is the maximum power available for a varying load for the duration of a main power network failure. The average load factor over 24 hours of operation should not exceed 70% of the engine's ESP power rating. Typical operational hours of the engine is 200 hours per year, with a maximum usage of 500 hours per year. This includes an annual maximum of 25 hours per year at the ESP power rating. No overload capability is allowed. The engine is not to be used for sustained utility paralleling applications.

Continuous Power (COP)

Continuous Power is the maximum power available for an unlimited period of use at a constant load factor. No overload capability is allowed.

Prime Rated Power (PRP)

Prime Power is the maximum power available for unlimited hours of usage in a variable load application. The average load factor should not exceed 70% of the engine's PRP power rating during any 24 hour period. An overload capability of 10% is available, however, this is limited to 1 hour within every 12 hour period.

- 1) All ratings are based on operating conditions under ISO 8528-1, ISO 3046, DIN6271. Performance tolerance of $\pm 5\%$.
- 2) Test conditions: 100 kPa, 25°C air inlet temperature, relative humidity of 30%, with fuel density 0.84 kg/L.
Derating may be required for conditions outside these; please contact the factory for details.

